

ergotron[®]

LearnFit™

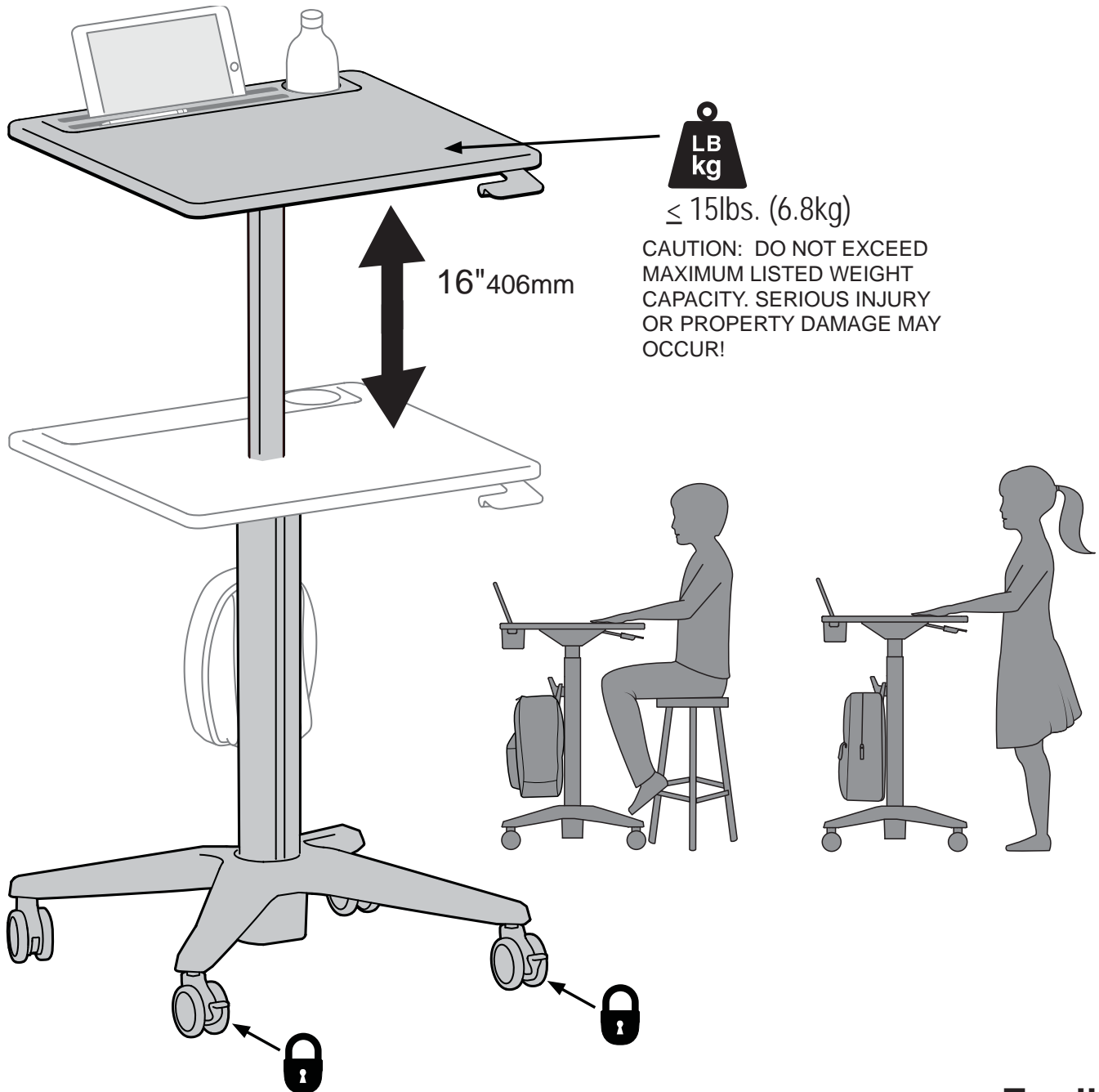

English



For the latest User Installation Guide please visit: www.ergotron.com

English, Español, Français, Deutsch, Nederlands, Italiano, Svenska, 日本語, 汉语

www.ergotron.com | USA: 1-800-888-8458 | Europe: +31 (0)33-45 45 600 | China: 400-120-3051 | Japan: japansupport@ergotron.com

Components

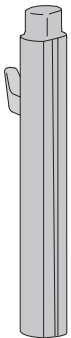
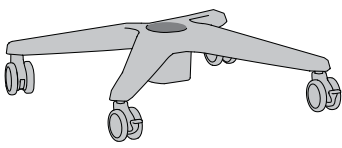
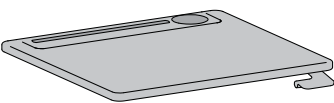

	A	B	C
1x		1x	1x
1			



Tools Needed



- 1** Remove base orientation indicator from base.

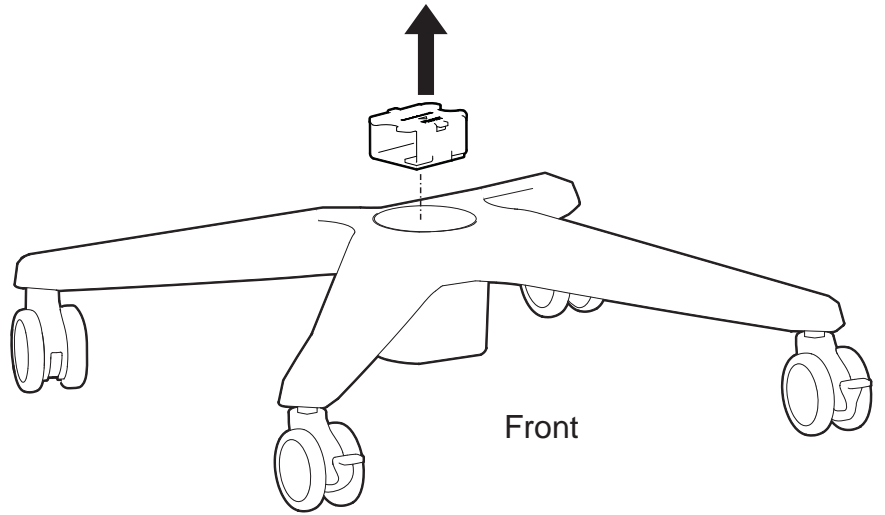
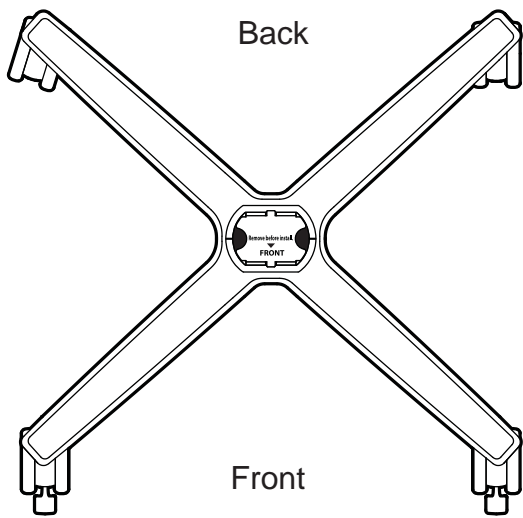

- 2** Partially insert riser into base.

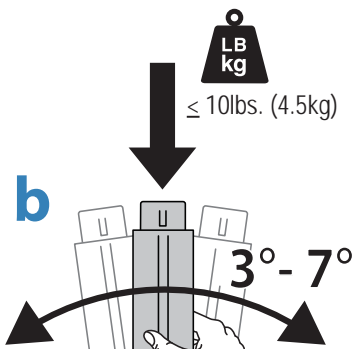
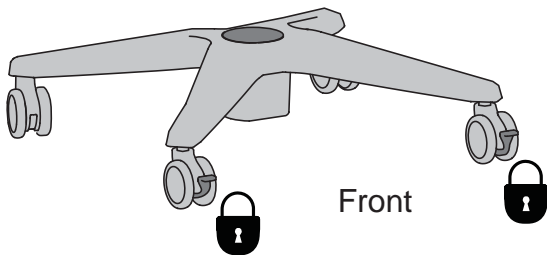
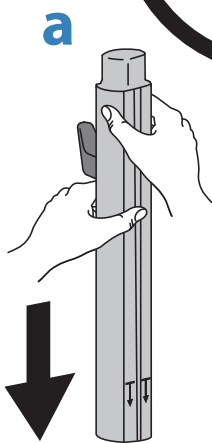

Rock riser from side to side while inserting.

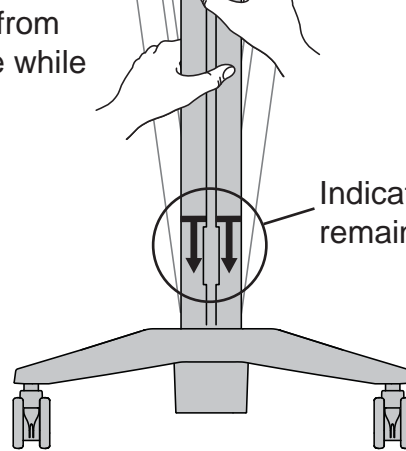

Indicator arrows will remain visible.

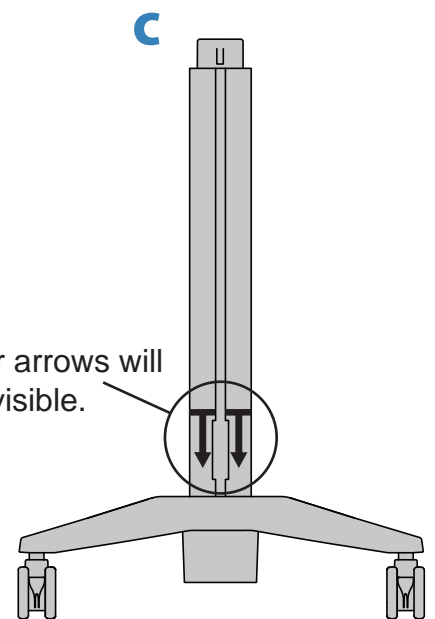

3 Remove cap.

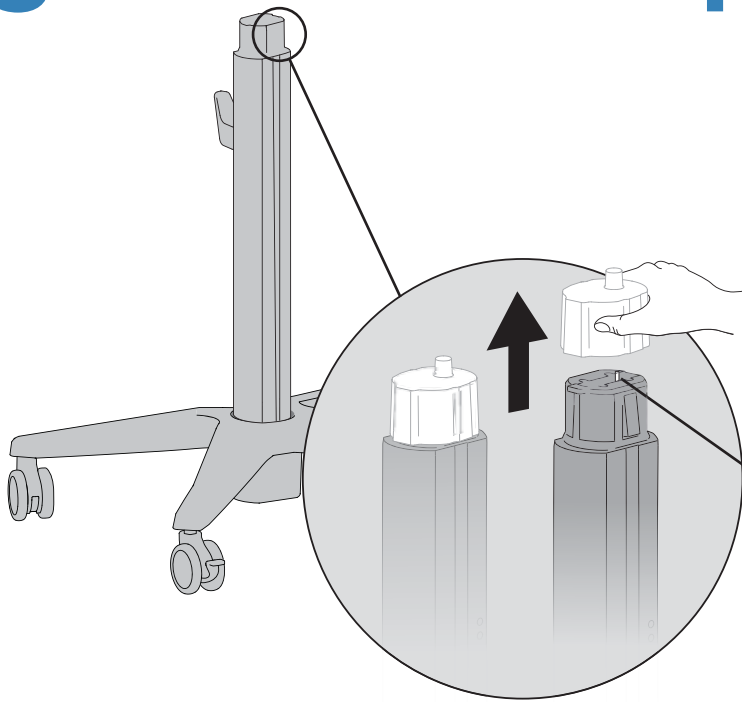

4 Attach work surface and press down.

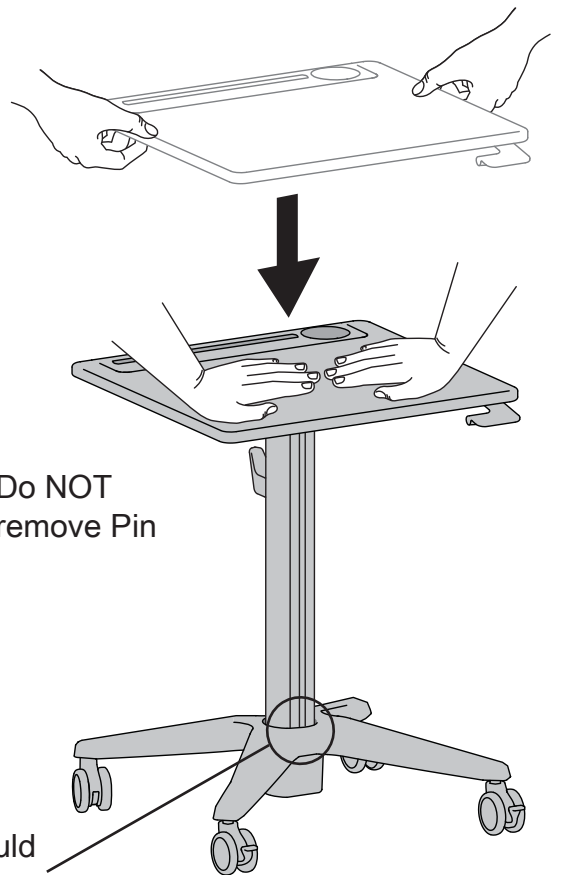

Do NOT
remove Pin

Indicator arrows should
be completely hidden.

5 Lift up on the work surface to make sure it is
securely attached to the base.

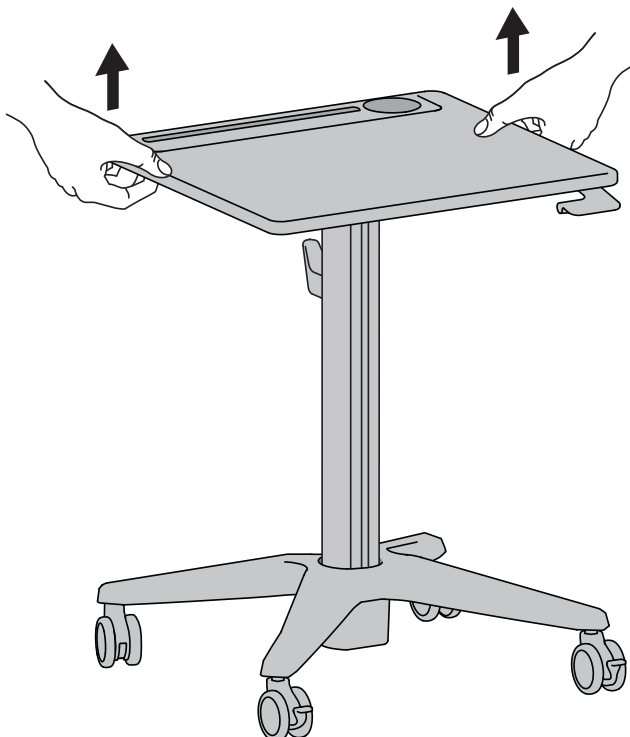

6

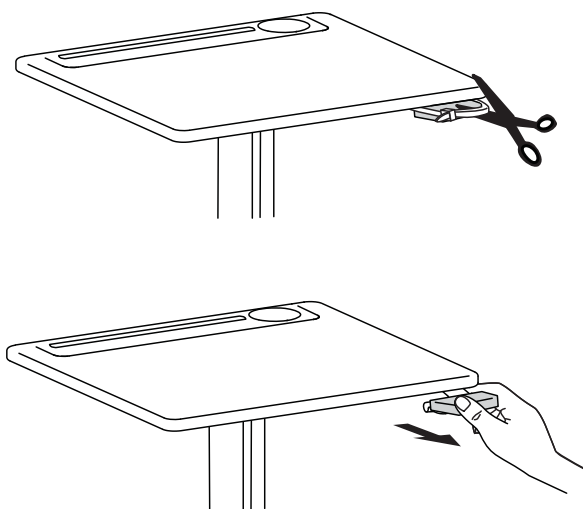

7

Lift brake release lever to raise and lower riser.

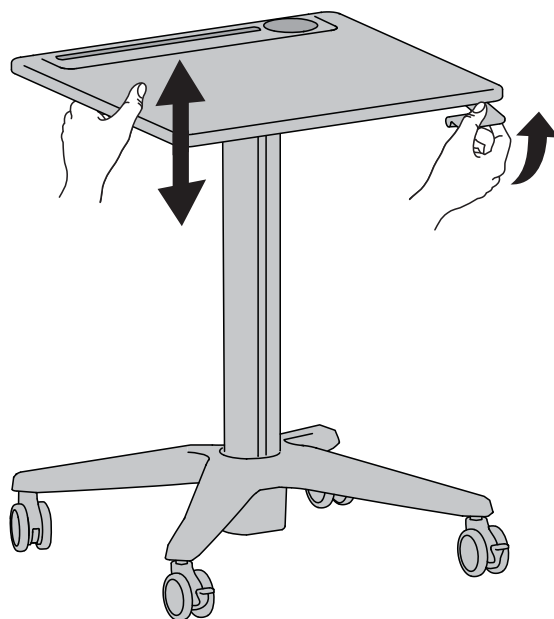

8

Loosen, but do not remove 2 screws to lift and lower hook to desired height.

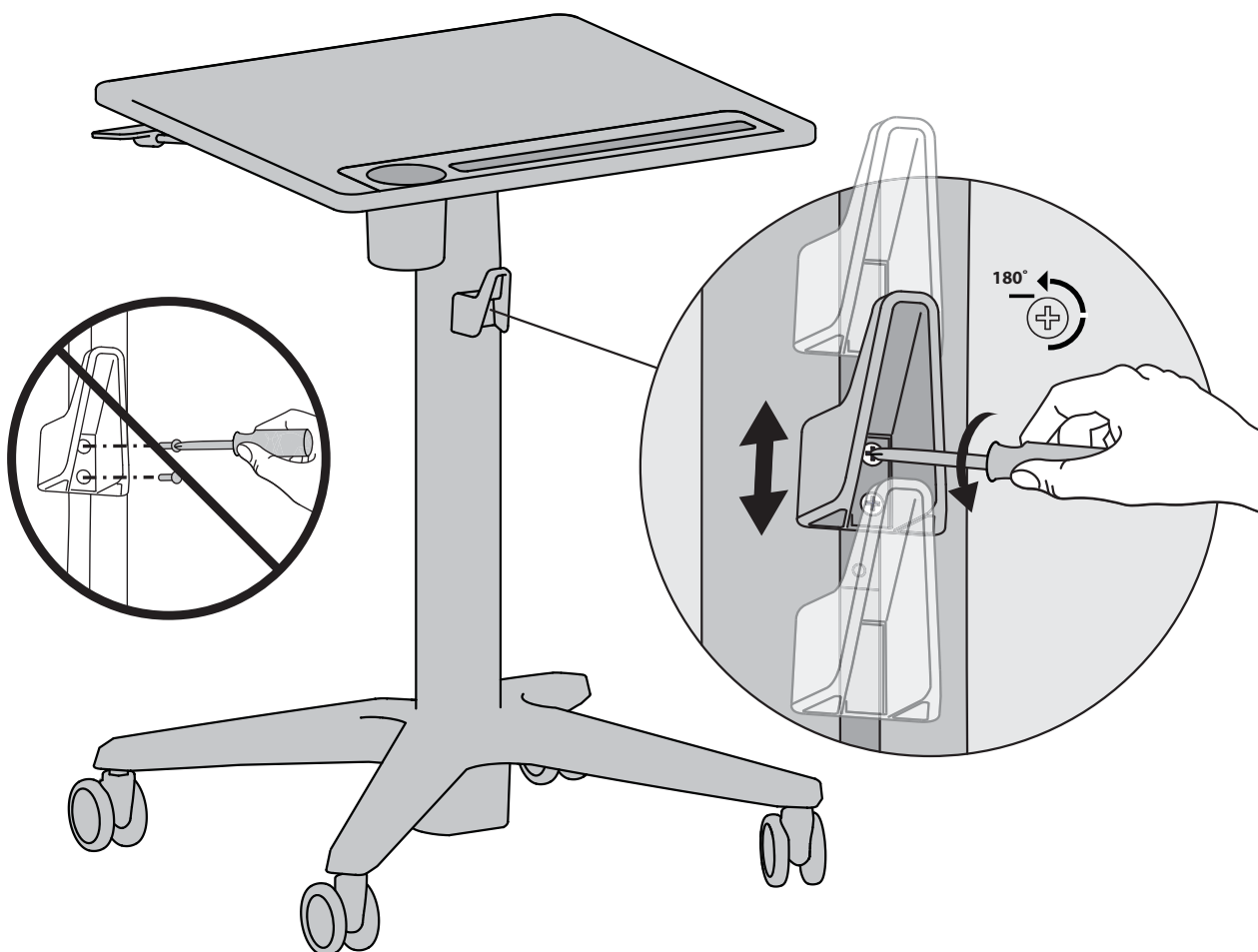

How to Disassemble

To remove worksurface,
push tab with a tool
while removing.
(Hex wrench suggested,
max diameter 4mm)

NOTE: Requires two
people.

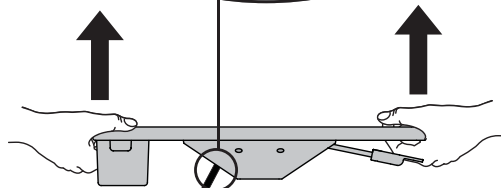
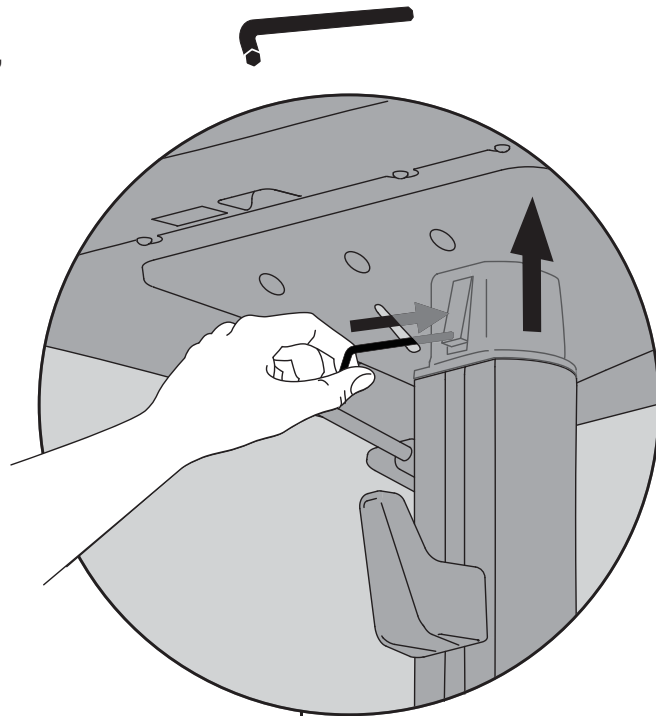

Attach cap.

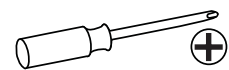
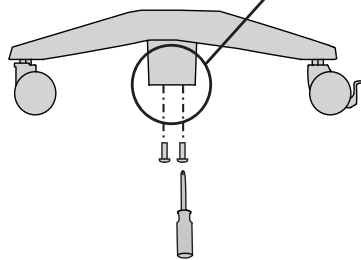
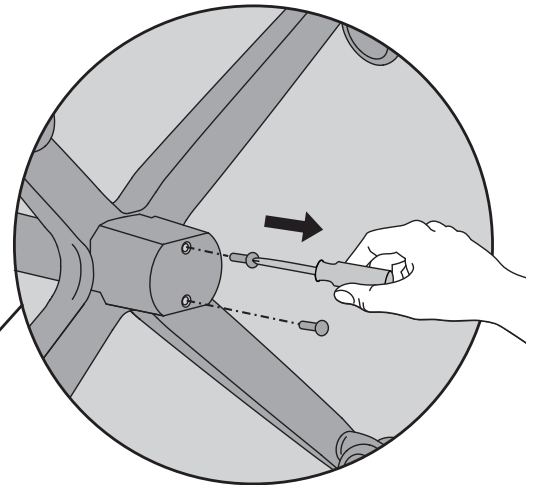
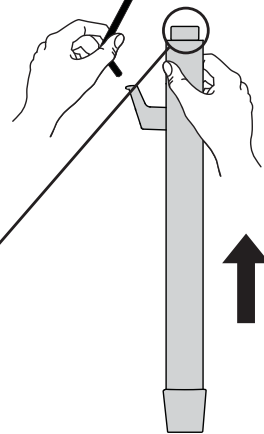
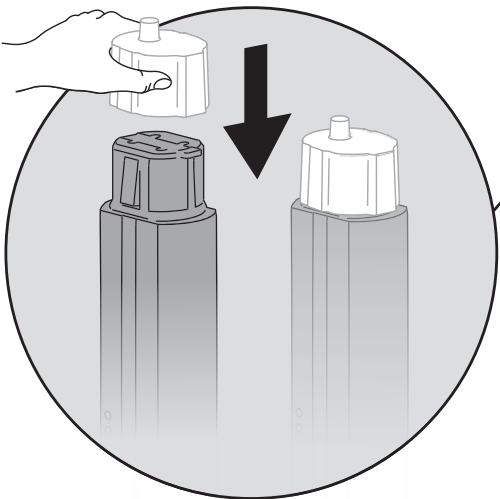

Set Your Workstation to Work For YOU!

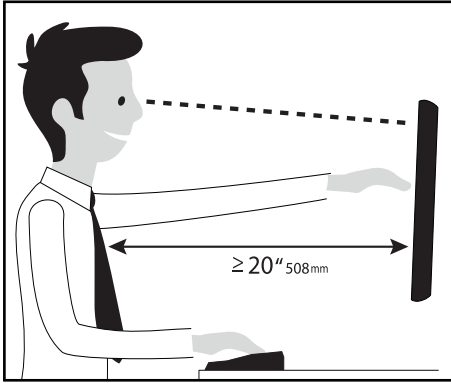

Learn more about ergonomic computer use at:
www.computingcomfort.org

- Height** Position top of screen slightly below eye level.
Position keyboard at about elbow height with wrists flat.
- Distance** Position screen an arm's length from face—at least 20" (508mm).
Position keyboard close enough to create a 90° angle in elbow.
- Angle** Tilt screen to eliminate glare.
Tilt the keyboard back 10° so that your wrists remain flat.

To Reduce Fatigue
Breathe - Breathe deeply through your nose.
Blink - Blink often to avoid dry eyes.
Break • 2 to 3 minutes every 20 minutes
• 15 to 20 minutes every 2 hours.

For Warranty visit: www.ergotron.com/warranty

For Service visit: www.ergotron.com

For local customer care phone numbers visit: <http://contact.ergotron.com>

NOTE: When contacting customer service, reference the serial number.

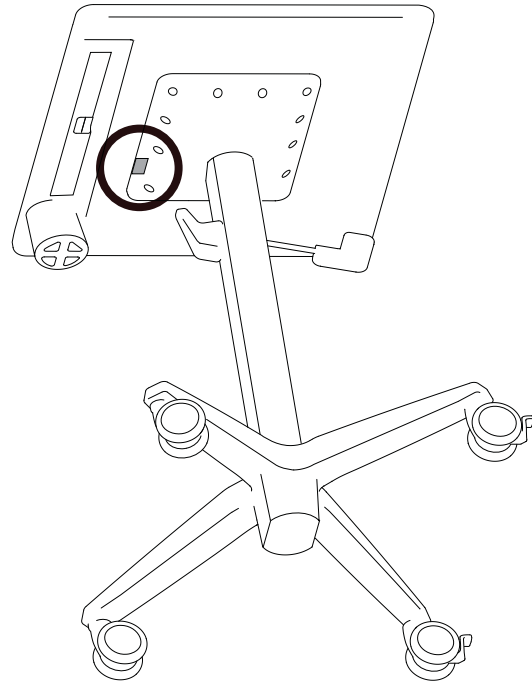

ergotron®

www.ergotron.com | USA: 1-800-888-8458 | Europe: +31 (0)33-45 45 600 | China: 400-120-3051 | Japan: japansupport@ergotron.com

© 2016 Ergotron, Inc. All rights reserved. LearnFit™ is a registered trademarks of Ergotron, Inc.

While Ergotron, Inc. makes every effort to provide accurate and complete information on the installation and use of its products, it will not be held liable for any editorial errors or omissions (including those made in the process of translation from English to another language), or for incidental, special or consequential damages of any nature resulting from furnishing this instruction and performance of equipment in connection with this instruction. Ergotron, Inc. reserves the right to make changes in the product design and/or product documentation without notification to its users. For the most current product information, or to know if this document is available in languages other than those herein, please contact Ergotron. No part of this publication may be reproduced, stored in a retrieval system, or transmitted in any form or by any means, electronic, mechanical, photocopying, recording or otherwise without the prior written consent of Ergotron, Inc., 1181 Trapp Road, Eagan, Minnesota, 55121, USA Patents Pending and Patented U.S. & Foreign. Ergotron is a registered trademark of Ergotron, Inc.