

ergotron[®]

26" Extension Tube for Zido[®]



Product	Part#
Zido Extension Tube	ZET26CG

NOTE: The Zido cart is not included.

PARTS LIST

Before beginning assembly of your 26" Extension Tube, please review the parts list to verify that your shipment is complete.

Zido Extension Tube	Quantity
01 Extension Tube 26"	1
02 Nylock Nuts	4

NOTE

A 7/32" drill bit and electric drill are required for this assembly.

A 3-way wrench is supplied for this assembly. If you have a 3/8" wrench or socket, use that instead.

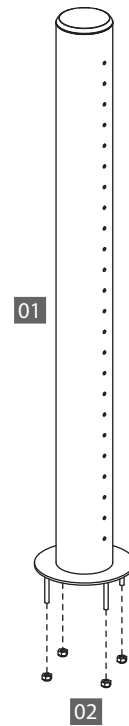

STEP 1

Drill the Top

- Place the cart shelf upside down on a non-marring surface that can stand to have some holes drilled into it.
- Locate the Extension Tube hole array of four 1/8" holes.
- Drill through these holes with the 7/32" drill bit.
- Complete your cart assembly.

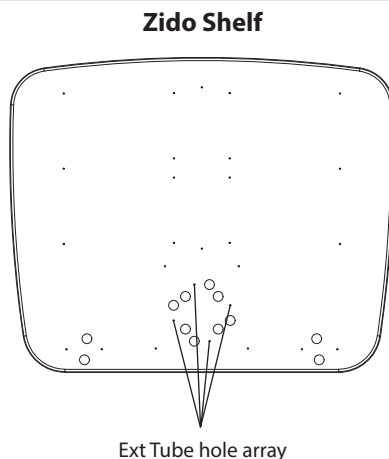

STEP 2

Install the Extension Tube

- Align the Extension Tube with the holes on the top of your cart. Make sure that the vertical hole array on the Extension Tube face the back of the cart.
- Slide the Extension Tube into place. Use the 3-way wrench (or your own 3/8" socket or wrench) to secure with the four nylock nuts.

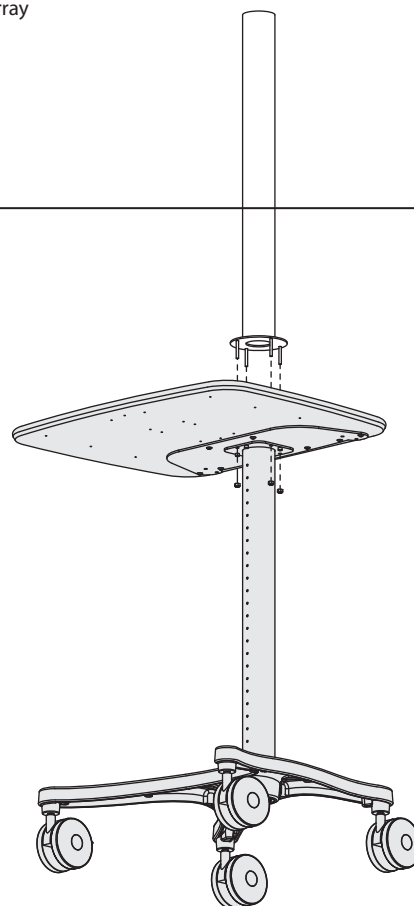

CONGRATULATIONS! YOUR EXTENSION TUBE ASSEMBLY IS COMPLETE!

ergotron®

For the latest User Installation Guide please visit: www.ergotron.com

For Warranty visit: www.ergotron.com/warranty

For Service visit: www.ergotron.com

For local customer care phone numbers visit: <http://contact.ergotron.com>

www.ergotron.com | USA: 1-800-888-8458 | Europe: +31 (0)33-45 45 600 | China: 400-120-3051 | Japan: japansupport@ergotron.com

© 2015 Ergotron, Inc. All rights reserved.

While Ergotron, Inc. makes every effort to provide accurate and complete information on the installation and use of its products, it will not be held liable for any editorial errors or omissions (including those made in the process of translation from English to another language), or for incidental, special or consequential damages of any nature resulting from furnishing this instruction and performance of equipment in connection with this instruction. Ergotron, Inc. reserves the right to make changes in the product design and/or product documentation without notification to its users. For the most current product information, or to know if this document is available in languages other than those herein, please contact Ergotron. No part of this publication may be reproduced, stored in a retrieval system, or transmitted in any form or by any means, electronic, mechanical, photocopying, recording or otherwise without the prior written consent of Ergotron, Inc., 1181 Trapp Road, Eagan, Minnesota, 55121, USA Patents Pending and Patented U.S. & Foreign. Ergotron is a registered trademark of Ergotron, Inc.